

Litens Automotive GmbH

Gelnhausen

Standards for Packaging and Shipping Parts by Suppliers



Logistics Guideline Manual:
Edition:
Contents and design:
Contact:

Status 05/2011
I
Martin Krefft
Logistik@litens.de

LAG / Logistic Manager
Martin Krefft

LAG – Packaging Designer
Sascha Frost

Logistics Guidelines



List of Contents

1	Introduction	8	<u>Shipment modes</u>
		8.1	Parcels
2	Packaging	8.2	Shipment by truck
2.1	Standard packaging	8.3	Shipment by rail
		8.4	Customs documents
3	<u>Reusable packaging</u>	8.5	Labels
3.1	Small load carriers (KLT/SLC)	8.6	Loading
3.1.1	Transport unit KLT/SLC	8.7	Processing times
3.1.2	Safe transport (reusable)	8.8	Delivery documentation
3.1.3	List of most frequently-used reusable	8.9	Extra / urgent deliveries
3.2	Procurement of reusable packaging		
3.3	Container management	9	<u>Goods labeling</u>
3.3.1	Adaptation of empties accounts	9.1	Master barcode label "M" version
3.3.2	Posting accounts	9.2	Single barcode label "S" version
3.3.3	Account reconciliation – inventory		
3.3.4	Container losses	10	<u>Logistics costs</u>
3.3.5	Container repair, handling	10.1	Packaging costs
		10.2	Freight costs
4	<u>Disposable packaging</u>		
4.1	Selecting disposable packaging	11	<u>Approval of deviations</u>
4.2	Loading units		
4.3	Cardboard delivering units		
4.4	Fastening cartons		
5	<u>Import/export cartons</u>	12	<u>Submission of proposals</u>
5.1	Specifications		
5.1.1	Categories		
5.2	Description of types		
5.2.1	Modular LAG export cartons		
5.3	Certification of origin of product		
6	<u>Wire mesh crates, pallets, EUR- /disposable pallets</u>		
7	<u>Shipments</u>		
7.1	Shipments Incoterms Group E and F		
7.2	Shipments Incoterms Group D		
7.3	Scheduled deliveries		
7.4	Interruptions in shipment process / transport		
7.5	Excess delivery / delivery ahead of schedule		
7.6	Determining weight		
7.7	Information obligations		
7.8	General ban on motor traffic		
7.9	Returns		

1. Introduction

Litens Automotive GmbH (hereinafter named LAG) has compiled this manual to establish uniform packing standards for its suppliers in order to assure consistently reliable and effective supply of parts to our customers.

Important issues such as planning, procurement and management of packaging material as well as parts labeling and delivery or pick-up will be explained on the following pages.

This manual applies to all LAG suppliers.

The logistics guidelines are thus also part of the framework or supply agreement concluded with the supplier. The supplier accepts the stipulations of the guidelines made available to him.

Any objections must be communicated in writing to LAG prior to signing contract.

Continuous improvement

LAG is consistently seeking to improve logistics.

The existing packaging and handling guidelines are under constant review; all suppliers are urged to cooperate in such improvement.

Any suggestions to improve the logistics chain may be submitted at all times to LAG material management.

The prime objective of logistics planning is to use customized reusable packaging meeting all cost-related and environmental requirements. The environmental objectives have their focus on conservation of raw materials and on avoiding waste, particularly hazardous waste.

2. Packaging

2.1 Standard Packaging

Standard packaging: Prior to any series shipments to LAG, a suited form of packaging will be defined for each article. Such definition will be based upon the LAG logistics guidelines, part-specific experience as well as pre-series parts or prototypes. The results of this preparatory work and any test packaging followed by transport analyses will be stated in the **Verpackungsvereinbarung (FB M 079 or PASDS)**, which states the defined type of packaging and filling amount per part. This packaging agreement will be signed by both contractual parties and is considered integral element of the contract. "If we receive no confirmation / feedback within 14 days, this packing instruction is confirmed."

If the defined standard packaging is not available, there will be an agreed alternative packaging, which in such exceptional case must be communicated to LAG's material management function prior to its use.

The supplier is obligated to assure rapid supply of the standard packaging and thus to restrict the use of alternative packaging to the shortest possible period of time.

The supplier shall be responsible for selecting the appropriate packaging material (type of container, dunnage, etc.).

The supplier is requested to quote packaging and dunnage in compliance with the Litens Guidelines.

The supplier's packaging proposals must take the following items into account:

- All parts must be reliably and safely packed to assure that there will be no impairments or damages during transport or storage, also over an extended period of time.
- As a general rule, reusable (returnable) packaging will be used for transports within Europe. Disposable containers will be used for transports outside Europe.
- The containers must be stackable – at least 3-fold also for disposable containers.
- To assure on-the-job safety, KLT/SLCs or small cartons may not weigh more than 12 kgs. Exceptions must be approved in writing and must be accepted by LAG.
- The supplied items / packaging may not feature any external labeling or identification (e.g. from upstream supplier or previous shipments).
- Any violation of the jointly agreed packaging agreement will be considered a quality defect and will be considered in the supplier assessment.

3. Reusable packaging

3.1 Kleinladungsträger / small load carriers – KLT/SLC

3.1.1 Transport unit VDA KLT/SLC

All standard VDA KLT/SLC types are admissible for use following prior agreement.

In order to assure consistent pallet stacking and maximum transport safety, all layers must be completely filled with KLT/SLC. If pallet-wide loading of the pallet is impossible, either use a smaller pallet or fill layer with empty packages.

In order to secure transport, always place a pallet lid over packaging unit.

All transport means (KLT/SLC, pallets and covers) must always be stated in the delivery slip. The loading units must be placed in staggered arrangement. Each KLT/SLC must feature a goods label according to VDA 4902. This label must be placed at a clearly visible position. The label may be applied only in the label envelope and/or as adhesive label. Single labels as well as master barcodes are explained under item 9.

Maximum KLT/SLC stacking height (*Lagenhöhe*) per euro pallet:

KLT-Typ	Lagenhöhe
3214	6
3215	6
4314	6
4315	6
4317	4
4321	4
4328	3
4329	3
6414	6
6428	3
6429	3

All KLT/SLC containers must be safely positioned on the transport pallets and must be fastened for transport. The containers will be fastened with plastic straps which have been selected for their ecological characteristics. The plastic straps must be made of PE or PP material and may not feature any metal elements (e.g. clamps).

The smallest purchase quantity is one KLT/SLC. Incomplete pallet layers must always be filled with empty KLT/SLC containers.

Differing KLT/SLC container types may not be stacked on one and the same pallet.

3.1.2 Safe transport (reusable)

Examples for correct and incorrect stacking of KLT/SLCs.

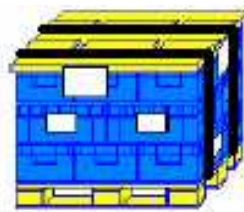
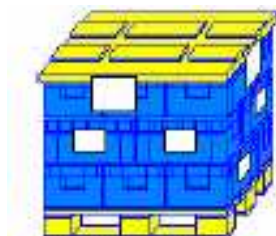

Correct

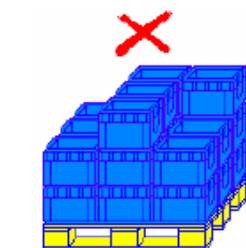



Incorrect

3.1.3 List of most frequently-used reusable containers at LAG

Designation	Dimensions	Container
EUR-Gitterbox, grau EUR wire mesh crate, gray	1200 x 800 x 1000 mm	
Kunststoffbox HDPE-0865 Plastic box	800 x 600 x 530 mm	
Kunststoffbox HDPE-1280 Plastic box	1200 x 800 x 1000 mm	
V-154 Stahlbehälter Steel container	1000 x 600 x 570 mm	
Pulleybox, grau	1000 x 720 x 750 mm	
EUR-Palette EUR pallet	1200 x 800 x 150 mm	
Kunststoff-Palette Plastic pallet	1200 x 800 x 170 mm	

Palettendeckel Kunstst. 1208 Plastic pallet lid	1200 x 800 x 080 mm	
KLT/SLC 3214	300 x 200 x 140 mm	
KLT/SLC 3215	300 x 200 x 150 mm	
KLT/SLC 4314	400 x 300 x 140 mm	
KLT/SLC 4315	400 x 300 x 147 mm	
KLT/SLC 4317	400 x 300 x 170 mm	
KLT/SLC 4321	400 x 300 x 210 mm	
KLT/SLC 4328	400 x 300 x 280 mm	
KLT/SLC 6414	600 x 400 x 140 mm	

KLT/SLC 6417	600 x 400 x 174 mm	
KLT/SLC 6421	600 x 400 x 210 mm	
KLT/SLC 6428	600 x 400 x 280 mm	

Maximum total weight of reusable packing unit is 800 kgs.

Important:

Do not apply any stickers or lettering to reusable packaging!

3.2 Planning and procurement of reusable packaging

Wherever possible, deliveries in Europe should always be made with suitable reusable packaging (wire mesh crates, KLT/SLC, thermo-formed foils, etc.). The supplier is responsible for planning and procurement of the reusable packaging in agreement with LAG's logistics function.

The supplier will always first make a trial shipment with the planned packaging.

The packaging agreement and procurement of the reusable packaging will be made only after such trial shipment has been made.

The reusable packaging must be made available and must be used at the time series production begins. Delivery with disposable packaging is acceptable in the project start-up phase (pres-series).

The supplier will procure the required packaging quantities for the packaging cycle on the basis of the anticipated annual volumes per project. Packaging repair requirements and losses will be taken into account in the procurement process.

3.3 Container management

3.3.1 Empties account, opening new empties accounts, management of reusable packaging

All transit quantities of reusable packaging required for shipments from supplier to LAG will be registered and administered in empties accounts by LAG container management. An empties account for supplier will be opened and managed per packaging type used. A supplier's empties accounts have a direct 1:1 ratio between the respective supplier and LAG.

LAG will open the empties accounts immediately after series packaging has been released. The empties accounts will register all account movement (incoming, outgoing).

The supplier will also maintain empties accounts for management of reusable packaging to be able to detect losses (chapter 2.2.4) in transit in due time and to react to these. The empties accounts must be able to register account movements. In compliance with LAG EDI – guidelines, the supplier will assure that all packaging quantities are registered at the same time the electronic delivery slip notification (remote data transmission) is sent.

3.3.2 Posting empties

All incoming and outgoing reusable packaging is registered in the LAG empties accounts. The reusable packagings (full packagings) delivered to LAG shall be considered incoming; the reusable packagings (empty packagings) leaving Litens shall be considered outgoing. The incoming posting shall be based upon the delivery slip or delivery slip notification; the outgoing posting will be made on the basis of the empties slip.

3.3.3 Account reconciliation - inventory

The supplier will receive monthly empties account statements from container management for review and confirmation of completeness. An annual closing inventory will be made each December. For this purpose, the supplier will receive the inventory data from LAG container management and will then make a physical closing day inventory on a day without any container movement. The inventory findings will be transmitted to LAG container management on the specified inventory formsheet. Inventory deviations must be clarified at short notice and may be clarified by correction postings to the LAG empties account, where applicable. The delivery slips are compared for this purpose. Only those delivery slips will be taken into account which state information on empties according to the LAG Logistics Guideline. Losses will be replaced by the contractual party responsible for the loss.

3.3.4 Losses

Losses shall be defined as those quantity deficits in reusable packagings, which cannot be accounted for in the monthly/annual inventories. Losses will be replaced by the contractual party responsible for the loss. The replacement value is stated in the packaging contracts and documentation.

3.3.5 Container repair, handling

The supplier will assure usability of the reusable packaging at his facility and, where required, will have these repaired by qualified specialized companies. Reusable packaging not in serviceable condition – as relates to on-the-job safety – may not be used for shipments to LAG or a company contracted by LAG.

Faulty deliveries to LAG in defective containers will immediately be communicated to the supplier by e-mail incl. enclosed photos and will be repacked at the supplier's expense. The defective containers will be held available for supplier pick-up or will be repaired at the supplier's expense.

LAG will take care of disposal of non-usable reusable packagings. The costs will be charged to the party responsible for the loss.

Packaging material is considered fit for use if it features no damages apart from external wear-and-tear and if further use will preclude any impairment of the parts to be delivered.

Containers will be made available and/or shipped broom-clean, irrespective of whether they are LAG property, supplier property or third-party property. If the cleanliness of the KLT/SLCs fails to meet the quality requirements of transported material, the supplier will be required to perform additional cleaning work at his expense.

More information is available in the LAG contract

- *Abwicklung von beigegebenen Verpackungen - FB M 062*
- *Bestandsabgleich Transportmittel - FB M 023*
- *Behälter Anforderung*

4. Disposable packaging

4.1 Selecting disposable packaging

The general use of disposable packaging is admissible only in overseas deliveries and in reasonable exceptions in Europe. All disposable packagings must be identified in compliance with standard DIN 6120 or by way of international recycling symbols.

One or multiple disposable cartons may be placed on a pallet. Maximum total weight of reusable packing units is 800 kgs. The containers must be stackable on pallets in three layers. If this is not warranted, stacking stabilizers must be integrated at the corners of the packaging unit.

On-the-job safety:

The supplier shall preferably use (HSC) cartons with removable lid, as these reduce the risks of personal injuries when unpacking with knives.

For dunnage, do not use compound materials (e.g. foam material bonded to corrugated cardboard) which are difficult to separate and recycle and are therefore not suited for these purposes.



HSC carton



RSC

The use of regular cartons (RSC) is not prohibited, but it is also not desirable.

A joint cover to top out the pallet both for HSC or RSC cartons on a pallet is the preferred method

4.2 Loading units

The standards for reusable packagings analogously also apply to disposable packagings.

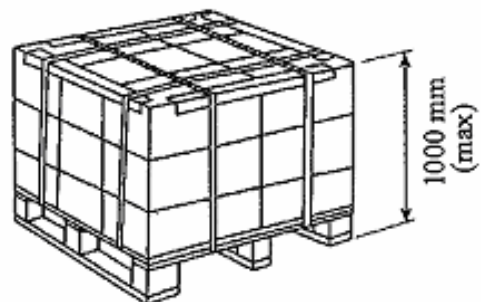
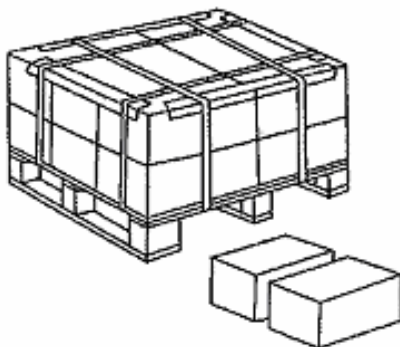

Maximum height including pallet is 1,000 mm.

4.3 Cardboard delivery units

The weight of an individual loading unit (small cardboard boxes) may not exceed 12 kgs (depends upon contents).

Incomplete box layers and non-stackable loading units and carton pyramids are inadmissible. Pallets must be stackable in three layers.

RICHTIG

Correct

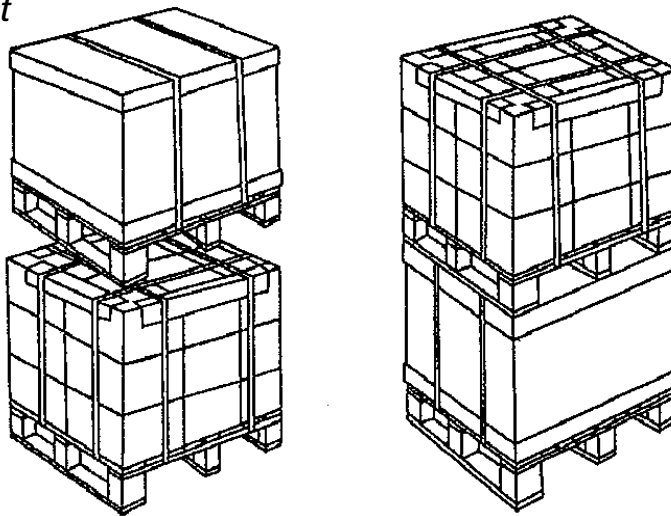

FALSCH

Incorrect

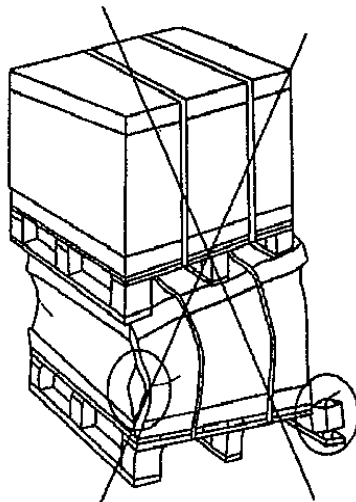

4.4 Fastening cartons

Loading units consisting of pallets and cartons must be secured in two directions with plastic straps. Under no circumstances may the plastic straps cut into the cartons. Where required for transport safety, attach vertical and horizontal corner braces for reinforcement. (The requirement for top cover lids is defined in the scope of packaging planning in compliance with the LAG Packaging Guidelines.)

RICHTIG

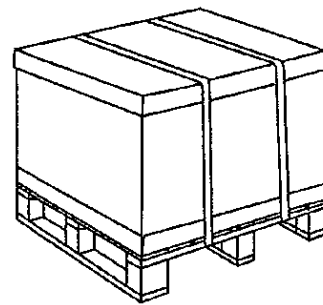
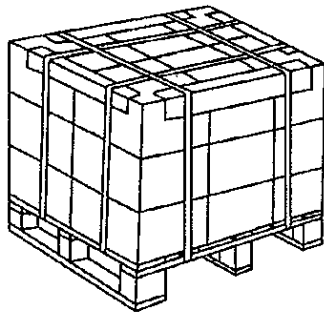

FALSCH

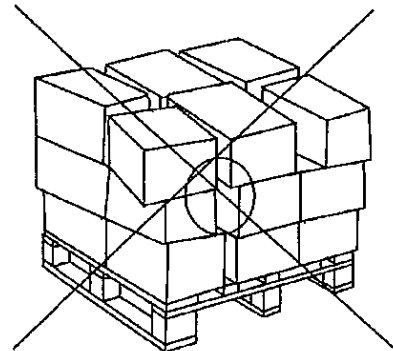
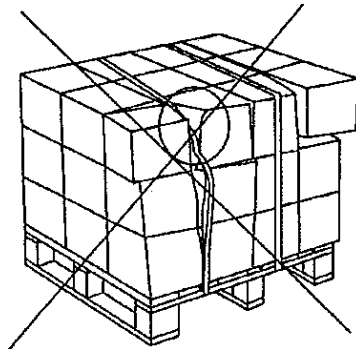

Stretch foils and steel straps are inadmissible!

(Exception: steel straps may be used to transport tools, steel coils, etc.)

5. Import/export cartons

In order to achieve an effective loading rate of >90% of seafreight containers, LAG developed the following import/export cartons. With this type of loading unit (pallet + carton), up to four packing units may be stacked. This import/export carton is suited for product-specific transports with or without inlays as well as bulk material and modular parts.

The import/export carton always features four squared lengths of conifer wood in the corners. (4.5 x 4.5 x 61 cm), to assure reliable stackability of up to four pallets. Maximum load capacity per import/export carton is 800 kgs.

5.1 Specification

		length	width	height
Import/export carton groß = (e.g. type „F“) large	exterior diameter:	1130	x 940	x 750 mm
	interior diameter	1050	x 900	x 600 mm
Import/export carton mittel = (e.g. type „FK“) medium	exterior diameter:	1130	x 940	x 500 mm
	interior diameter:	1050	x 900	x 300 mm
Import/export carton klein = (e.g. type „FKK“) small	exterior diameter:	1130	x 940	x 310 mm
	interior diameter:	1050	x 900	x 150 mm

5.1.1 Categories

There are the following types of import/export cartons:
Acc. to item 5.1

Type (large)

- A 6 layers on top of each other with 80 compartments each (total 480 compartments).
incl. PE – foam foil and foil bag, heat-treated pallet, 31 kg
- B 4 layers on top of each other with 36 compartments each (total 144 compartments).
incl. PE – foam foil and foil bag, heat-treated pallet, 30 kg
- C 4 layers on top of each other with 18 compartments each (total 72 compartments).
incl. PE – foam foil and foil bag, heat-treated pallet, 30 kg
- D 6 layers on top of each other with 6 telescope boxes each (total 36 cartons).
Per telescope box with 15 compartments, incl. PE – foam foil and foil bag, heat-treated pallet, 48 kg
- E 7 layers on top of each other with 20 compartments each (total 140 compartments).
incl. PE – foam foil and foil bag, heat-treated pallet, 30 kg
- F Carton is empty, with only three intermediate layers, use as required.
incl. PE – foam foil and foil bag, heat-treated pallet. 25 kg
- G 6 layers on top of each other with six telescope boxes each (total 36 cartons).
incl. PE – foam foil and foil bag, heat-treated pallet. 55 kg
- H 6 layers on top of each other with six telescope boxes each (total 36 cartons).
Per telescope box one center traverse, longitudinal. incl. PE – foam foil and foil bag, heat-treated pallet, 47 kg

- I 9 layers on top of each other with 35 compartments each (total 315 compartments).
incl. PE – foam foil and foil bag, heat-treated pallet,. 32 kg
- K 9 layers on top of each other with 42 compartments each (total 378 compartments).
incl. PE – foam foil and foil bag, heat-treated pallet, 35 kg
- L 7 layers on top of each other with 143 compartments each (total 1,001 compartments).
incl. PE – foam foil and foil bag, heat-treated pallet, 35 kg
- M 6 layers on top of each other with 12 telescope boxes each (total 72 cartons).
Per telescope box two traverse sets on top of each other, 12-fold compartment
incl. PE –foil bag, heat-treated pallet, 57 kg

Type FK (medium)

- K Export carton FK, empty. (small, only half height), incl. PE – foil bag, heat-treated pallet, 22 kg
- AK Export carton FK, incl. foil bag, empty plus:
3 x intermediate layers incl. PE-foam, 3 x traverse set, heat-treated pallet, 25 kg
- HK 3 layers on top of each other with six 6 telescope boxes each (total 18 cartons).
Per telescope boxes one traverse, longitudinal. incl. PE – foam foil and foil bag, heat-treated pallet. 33 kg
- MK 3 layers on top of each other with 12 telescope boxes each (total 36 cartons).
Per telescope box two traverse sets on top of each other, 12-fold + 1 x intermediate layer., incl. PE-foil bag as well as lateral cardboard as dunnage, heat-treated pallet, 36 kg

Type FKK (small)

- FKK export carton FK, empty. (small, quarter height), incl. foil bag, heat-treated pallet, 22 kg

Depictions of the types are found under item 5.2.

Other models will be designed and added to the list as required..

5.2 Description of types

Export carton large, type F:

900104

Carton is empty, with only three intermediate cardboard layers, use as required.
incl. foil bag,
Pallet and stacking timber interior heat-treated
Tara: 25.0 kg



Export carton medium, type FK:

900189

Export carton FK, empty. (small, only half height)
incl. foil bag,
Pallet and stacking timber interior heat-treated
Tara: 22.0 kg



Export carton small, type FKK:

900351

Export carton FK, empty. (small, only quarter height)
incl. foil bag,
Pallet and stacking timber interior heat-treated
Tara: 19.0 kg



Logistics Guidelines

5.2.1 Modular interior packaging

Small cartons inside the two import / export cartons

In order to assure optimal filling of the import/export cartons, LAG holds available a modular interior packaging solution. All relevant purchase parts can thus be packed to facilitate handling. Inlays and type of packaging in the small cartons must be agreed with and approved by LAG (chapter 10). You will find the dimensions in chapter 5.

Example 1- interior carton K0500 - LAG part no.: 900117
Exterior dimensions: 500 x 300 x 147 mm
Large version = 24 x cartons possible (**in type F**)
Medium version = 12 x cartons possible (**in type FK**)

6 x cartons per layer
and 2 or 4 layers high



Example 2 – interior carton K0250 - LAG part no.: 900301
Exterior dimensions: 250 x 300 x 147 mm
Large version = 48 x cartons possible (**in type F**)
Medium version = 24 x cartons possible (**in type FK**)

12 x cartons per layer
and 2 or 4 layers high



Example 3 – interior carton K0125 – LAG part no.: 900302
Exterior dimensions: 250 x 150 x 147 mm
Large version = 96 x cartons possible (**in type F**)
Medium version = 48 x cartons possible (**in type FK**)

24 x cartons per layer
and 2 or 4 layers high



5.3 Certification of origin of product and preferences

If the supplier has his place of business and/or production site within the European Union, the supplier must make a supplier declaration in compliance with VO (EG) 1207/2001 (single declaration or long-term declaration) in compliance with the applicable EC regulations.

The suppliers will receive a formsheet for the annual declaration. The supplier will send the signed formsheet back to LAG within two weeks of receiving the formsheet, however no later than delivery to LAG.

If the supplier as an exception makes the supplier declaration on his own formsheet or by remote data transmission, this must previously be approved by LAG.

If the supplier has his place of business and/or production site within a country which has a free-trade agreement with the EU, he will issue a preference certificate (movement certificate / declaration of origin on the invoice) for each shipment. The stipulations of the free-trade agreement must be observed.

6. Pallets / wire mesh crate

EUR pallet / disposable pallets

Pallets must be designed as shown below.

Pallets with other sizes or designs must be approved by LAG.

You will find deviating dimensions for export/import for optimum loading of sea-freight containers as well as requirements on stackability in chapter 5.

All wooden pallets and wooden components designated for overseas transports must comply with the international IPPC standard.

The valid symbol for this standard looks as follows:

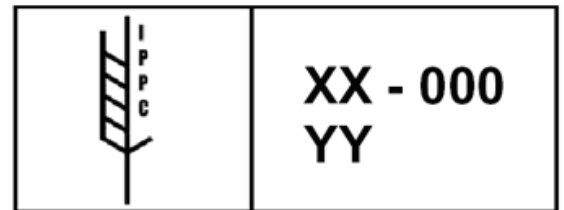
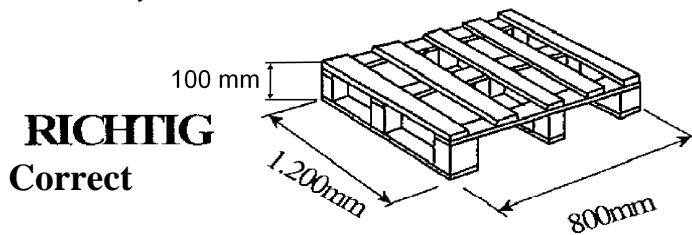

FALSCH

Incorrect

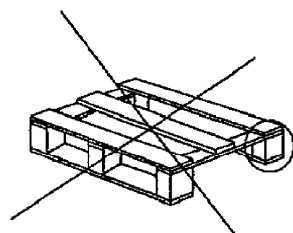
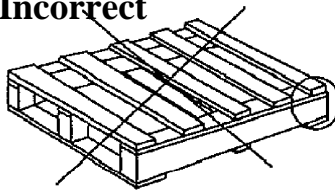

Palette in halber Größe

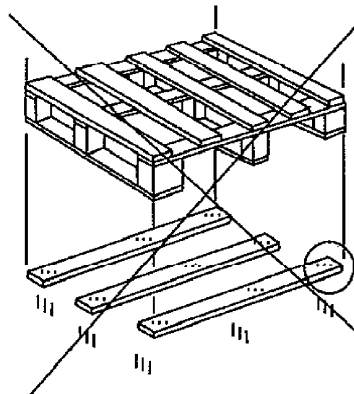

Palette mit allseitigen
Unterzügen-
3 zusätzliche Bretter
unterwärts befestigt,
wie abgebildet



Drive-under height of 100 mm is mandatory to assure fork-lifters may be used at all times.

The EUR-wire mesh crate, gray

The wire mesh crate is the most widely-used GLT container throughout Europe.

It may be used as reliable transport means for bulk freight as also as outer package for thermoformed foils and/or other reusable transport elements.



Exterior dimensions: 1240 x 835 x 970

Interior dimensions: 1210 x 800 x 800

Max. load manufacturer information: 1,000 kgs – (Litens rating: 500-800 kgs)

Inner lining must comply with packaging instructions, which are previously agreed with LAG. Bent and defective GLTs may not be used for transport. Stackability and transport reliability must be assured at all times.

7. Shipments

7.1 Shipments according to Incoterms 2011/Groups E and F

If shipment is "FCA (...named places)" or any other shipment mode in compliance with Incoterms 2011 Groups E and F has been agreed, the supplier will hand over the goods only to the carriers specified by LAG.

If the supplier contrary to the stipulated terms of shipment terms delivers the goods to LAG himself, he shall bear all risks until parts are accepted by LAG.

7.2 Delivery acc. to Incoterms 2011/Group D

If the supplier hires the carrier himself, the carrier to be hired and the vehicle configuration will be agreed with LAG Logistics and/or material management function.

7.3 Scheduled delivery

Scheduled delivery will be clearly identified as such for the carrier and LAG Incoming. The supplier will state delivery day and time at LAG on the carrier's orders, which will be given to the carrier. Any deviations from the agreed arrival time slot will previously be agreed with LAG Incoming and/or material management function.

7.4 Interruptions in shipment process / transport

Any interruptions in the scheduled progress, which shall also include interruptions caused by subsuppliers, will immediately be communicated by the supplier and/or the carrier to the competent LAG material management function by telephone and e-mail/telefax. Such communication will state the exact reasons for and the type of interruption. Any interruptions will be immediately remedied.

7.5 Excess delivery / delivery ahead of schedule

The supplier is authorized to make partial deliveries, deliveries prior to call-off as well as additional deliveries only with prior written approval by LAG. If the supplier hands over the goods to a carrier, forwarding company, etc. in disregard of this stipulation, the supplier shall bear all risks until parts are accepted by LAG. The supplier shall bear the logistics costs for storage and/or return of unauthorized excess delivery / delivery ahead of schedule.

7.6 Determining weight

The supplier is responsible for properly determining the shipment's gross weight and tare weight. If the weight particulars are incorrect, LAG will charge the additional freight plus a processing fee to supplier's account.

7.7 Information obligations

Changes to outshipment location, e.g. due to transferal of production to a different supplier plant or installation of a shipment warehouse away from the prior location, will be communicated in writing to Purchasing, Logistics, the plant's material management, container management as well as the competent carrier at least four weeks prior to the transferal.

7.8 General ban on motor traffic

If delivery conditions acc. to Incoterms 2011/Group D apply, the supplier will assure that goods will be delivered in the event there is a general ban on motor traffic.

7.9 Returns

Any return transports due to the supplier's fault will be organized by LAG, unless something different had been previously agreed. The supplier will bear the costs.

8. Shipment modes

8.1 Parcel

If shipment is "FCA (...named places)" or any other shipment mode in compliance with Incoterms 2011 Groups E and F has been agreed, all parcels with a weight of up to 32 kgs will be handed over to the parcel services specified by LAG.

8.2 Shipment by truck

The supplier will assure that all carrier personnel engaged with providing services for LAG meets the requirements in pertinent regulations (§§ 7b and c GüKG). LAG reserves the right to verify and document compliance with this obligation as provided by law. To the extent within the supplier's scope of responsibility, the supplier in the event of non-compliance with this obligation will hold LAG harmless against third-party claims.

8.3 Shipment by rail

Shipment by rail is admissible only if explicitly requested by LAG and if the processing particulars have been agreed upon in writing.

8.4 Customs documents

All customs documentation and information will be made available to the carrier e.g. preference certificates (EUR. 1, UZ Forma A and commercial invoice in triplicate).

8.5 Labels

A bar-coded (Code 39) label in compliance with VDA recommendation 4902 (in the respectively applicable newest version) will be attached to all packing units and load carriers (in containers all single KLT/SLC / cartons). The field contents as well as any deviations from the above VDA-recommendation are stated in chapter 8.

8.6 Loading

Loading and processing will be done immediately after vehicles are ready. If the supplier is in charge of loading, he will load the goods in a safe manner and will follow the instructions of the forwarder's personnel.

More details on safe loading of LAG load packagings are found in chapters 3.1.2 and 3.1.3.

8.7 Processing time

Upon request by carrier or LAG, the supplier is obligated to record the beginning and the end of time the vehicle is made available. Delayed processing and excessive loading and waiting periods will cause additional costs to be borne by the supplier.

8.8 Delivery documentation

If LAG determines damages or incorrect delivery items at the time of delivery, LAG may request the supplier inside of two workdays to submit a written statement on the undamaged and complete hand-over of the shipment to the carrier hired by LAG.

8.9 Extra / urgent deliveries

Short-term urgent deliveries are usually organized by the supplier and are done by the carrier or parcel service chosen by LAG in cooperation with the supplier. Such approval will as a rule be issued by LAG material management in cooperation with the supplier. LAG will allocate and charge the costs for extra/urgent deliveries to the party that caused them.

9. Goods labeling

9.1. Master barcode label " M" Version

This specification describes the LAG standard in effect for preparing and applying barcode labels acc. to VDA 4902. This is required to assure the productivity and monitoring of materials by efficiently recording data for the following processes:

Incoming, warehousing, removals, consumption in production, periodical inventories, and other inventories.

All transport units (GLT or pallet unit) must feature such a master label (M-Label) to assure reliable identification of the contents. Goods labeling for all packagings must be made in compliance with the topical VDA 4902.

Example for positioning the master label (KLT/SLC)

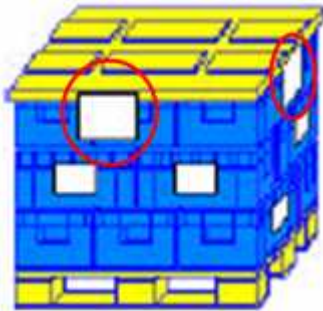

Description of master label:

- white cardboard/adhesive label size 210 x 148 mm.
- label font "Arial".
- text in German or English (black lettering)
- character size must be readable for the human eye.
- one master label at front, another one at the side

Logistics Guidelines

(1) Warenempfänger		(2) Abladestelle - Lagerort - Verwendungsschlüssel		
(3) Lieferschein-Nr (N) 908146943 		(4) Lieferantenanschrift (Kurzname, Werk, PLZ, Ort) Max Mustermann GmbH		
		(5) Gewicht netto 400	(6) Gewicht brutto 450	(7) Anzahl Packstücke 2
(8) Sach-Nr Kunde (P) 11210201218A 				
(9) Füllmenge (Q) 560  ST		(10) Bezeichnung Lieferung, Leistung		
		(11) Sach-Nr Lieferant (30S) 123456789 		
(12) Lieferanten-Nr (V) 57349611 		(13) Datum D 07.08.20		
		(14) Änderungsstand Konstruktion		
(15) Packstück-Nr (S) 440010300010340 		(16) Chargen-Nr (H) 1481781001 		
(17) Max Mustermann GmbH		Warenanhänger VDA 4902, Version 4		

1. Goods recipient	Address of Litens Automotive GmbH
2. Unloading address	Receiving plant (Gelnhausen)
3. Delivery slip number	Delivery slip number
4. Supplier address	Sender (supplier)
5. Weight net (kg)	Weight of goods
6. Weight gross (kg)	Total weight of shipment
7. Quantity of packing units	Quantity of packing units on the pallet
8. Customer item no.	Customer's item/article number
9. Filling quantity	Quantity of delivered parts
10. Designation delivery	English or German designation of article
11. Supplier item number	Supplier's item/article number
12. Supplier code.	Supplier ID code issued by LAG
13. Shipping date	The day the shipment leaves supplier facility
14. Change level	Please state if article design/engineering was changed
15. Packing unit number	State for pallets with cartons (e.g. 2/12)
16. Batch no.	Production batch no.

9.2. Single barcode label "S" Version

Each single unit (KLT/SLC or single carton) must feature such a single label S-label) for reliable identification of the contents. Goods labeling for all packagings must be made in compliance with the topical VDA 4902.

Example for position of single label (KLT/SLC)



Description of single label

- white cardboard size 210 x 148 mm
- for KLT/SLC units, the label must be inserted in the designated holder
- black lettering and label font "Arial".
- text in German or English.

(1) Warenempfänger	(2) Abladestelle - Lagerort - Verbrauchsstelle	(3) Lieferschein-Nr. (N) 12345678
(8) Sach-Nr. Kunde (P) 42386703600B		
(9) Füllmenge (Q) 40 ST	(10) Bezeichnung Lieferung, Leistung	
(12) Lieferanten-Nr. (V) 90033759	(11) Sachnummer Lieferant 6428-01	
(15) Packstücknummer (S,M,G) S123456789	(13) Versanddatum D 07.08.14	(14) Änderungsstand Konstruktion RevStd 09
	(16) Chargen-Nr. (H) 1234567	

Please note:

Labeling must always be clear and definite. Please always remove all expired labels from the reusable packagings. The supplier is responsible for removing all old labels.

10. Logistics costs

10.1 Packaging costs

All packaging cost elements must be clearly identified and they must be listed in the supplier's quotation in addition to the price per unit. LAG Purchasing will review these packaging costs and will negotiate these with the supplier for the duration of the contract.

10.2 Freight costs

All freight cost elements must be clearly identified and they must be listed in the supplier's quotation in addition to the price per unit. LAG Purchasing will review these freight costs and will negotiate these with the supplier for the duration of the contract. Litens will communicate and/review the customs levies and customs tariff codes.

11. Approval of deviations from binding logistics guidelines

An approval of deviation may be applied only if the supplier cannot provide the agreed packaging or the type or schedule of delivery for justifiable or feasible reasons.

Any applications will have to be made at least 2 – 3 weeks prior to the delivery date.

LAG will approve any such application only on the basis of written applications. LAG reserves the right to approve, to decline or to change these.

Should any additional costs arise due to the deviation approval, these will be charged to the account of the party causing such additional costs.

If the supplier fails to comply with the approved deviation, LAG will be entitled to recover costs from the supplier arising in context with small-volume deliveries, loss in quality, breakage, production stoppage and all other subsequent costs.

12. Submission of proposal

The formsheet **FB M 079** shall be used for all packaging planning.

- product data such as size and weight
- disposable, reusable
- production in/outside Europe
- size and weight of intended packaging (single containers not more than 12 kgs due to internal on-the-job safety regulations)
- stackable on three levels, maximum height of packaging unit 1,000 mm (due to internal storage system).
- containers (pallets, wire mesh crates, KLT/SLC, GLT etc. in compliance with European standards) must be suited for forklift drive-under (at least 100 mm floor clearance to assure that pallets can be conveniently transported with pallet cart or forklift).
- product-specific data: anti-corrosion, PE-foam, traverse sets, etc.

When using **import/export cartons (disposable)**, compliance with the following requirements is mandatory:

- pallet size: 1130 x 940 x 750 mm
- outer carton fastened to the pallet
- squared lengths of wood at each corner in size 4.5 x 4.5 cm in order to assure stackability of three pallets
- pallets must be suited for forklift drive-under (at least 100 mm floor clearance to assure that pallets can be conveniently transported with pallet cart or forklift)
- observe straps guidelines
- state customs tariff code.

All requirements stated above must be listed in formsheet FB M 079 and must be documented with photos.

Litens must approve all packaging planned by the supplier.